

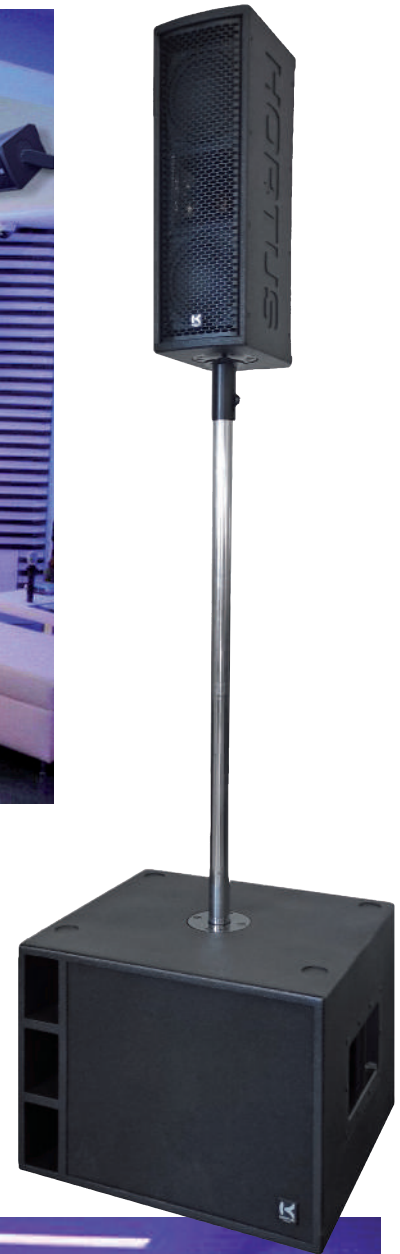

NEW
HORTUS AUDIO - CR251
Active or 2-Way Passive Speaker



- Class D Amplifier**
- 500 + 150 W RMS
 - 2 X 5" WOOFER + 1.5" VOICE COIL
 - 1" NEODYMIUM COMPRESSION DRIVER



Its accuracy and intelligibility make it **ideal for karaoke**. Easy to install with its U-bracket and to set up. It can be combined with a variety of subwoofers, as shown here with the MB1.





CR251P - 2-Way Passive Speaker

- **LF:** 2 x 5" woofer, 1.5" voice coil
- **HF:** 1" Neodymium compression driver
- **Directivity:** 90° x 60° (Horn easy rotatable via 4 screws)
- **Bandwidth:** 70 - 20 kHz
- **AES Power:** 340 W @ 8 Ω
- **Connections:** 2 Speakon NL4MP

OTHER SPECIFICATIONS:

- **Rigging:** 2 x M20/M10 Top & Bottom
- Baltic birch wood
- Black or White finished polyurethane paint
- Acoustically neutral 3D fabric (black, white or gold))
- **Dimensions:** H480 x D250 x W160 mm
- **Weight:** 10 Kg

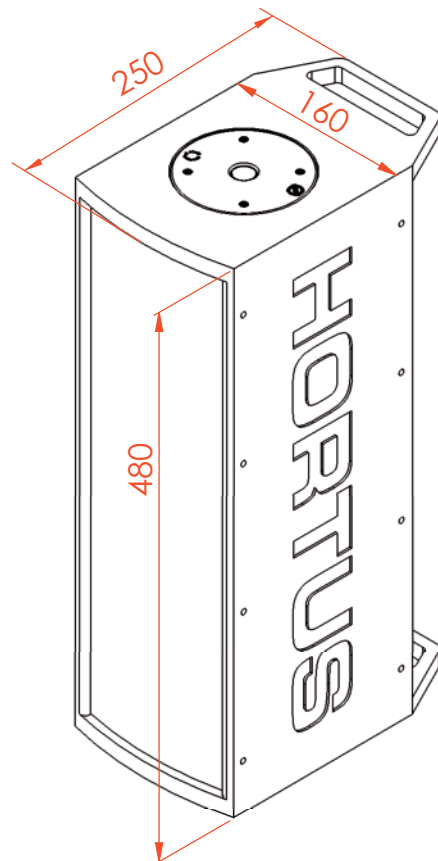

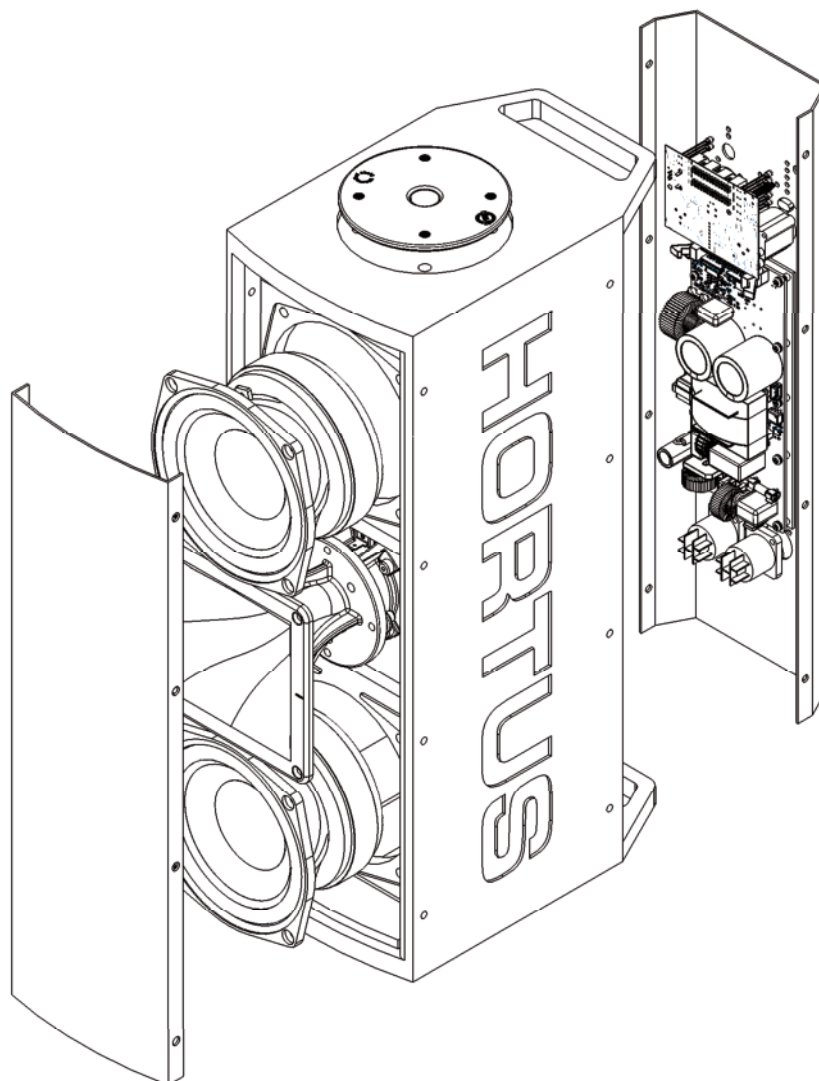

SIGNAL :

- Input: Bal./Unbal. Female XLR
dynamic range 114dB(A) / input level: +6dBu
- Output: Male XLR

PROCESSOR SECTION: (All DSP Germany)

- Mixed-mode 64 bits digital processing
- 96kHz sample rate
- 114dB(A) dynamic range (input & output)
- Frequency range 10Hz - 40kHz
- 10 parametric filters on each input and each output
- 10ms delay on each output
- Butterworth, Bessel, Linkwitz-Riley filters 24dB/oct.
- Limiter on each input and each output
- 180° phase
- Input level: Nominal +6dBu / Max +21dBu
- Output level: Nominal +11dBu / Max +12dBu
- 5 x factory DSP presets
Selection via switch or software with 5 Leds
P1: Full Range - P2: Flat - P3: Music
P4: Voice - P5: Speech
- 25 users presets via software
- Gain control via potentiometer
- Ethernet interface
- Full configuration and real-time monitoring via PC
- Control Software: Windows 32 & 64 bits + Mac OS

POWER SECTION:

- 2 x Class D amplifier Pascal Audio (Denmark)
- TOTAL Power: 650 Watts RMS / 1300 W Peak
- LOW Frequencies: 500 W RMS / 1000 W Peak
- HIGH Frequencies: 150 W RMS / 150 W Peak
- Power: from 85V to 265V AC
- Connection Power IN/OUT: Powercon

TRANSDUCTERS :

- LF 2 x 5" woofer, 1.5" voice coil
- HF 1" Neodymium compression driver
- 90° x 60° coverage (Horn easy rotatable via 4 screws)
- 2 x M20/M10 Top & Bottom internal fixing for rigging
- 70 - 20000 Hz Frequency range

OTHER SPECIFICATIONS:

- Cabinet material: Premium grade Baltic birch plywood
- Color: Black or White (custom color on request)
- Grille: Steel
- Acoustically neutral 3D fabric (black, white or gold))
- Dimensions: 480 x 250 x 160 mm
- Weight : 11 Kg